

U.S. General

Bucket Grease Pump

Model 91793

ASSEMBLY AND OPERATING INSTRUCTIONS

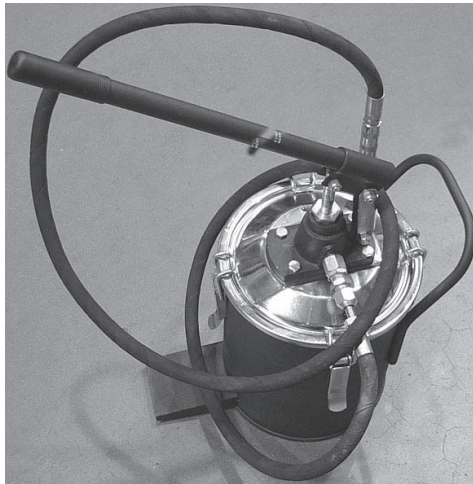

3491 Mission Oaks Blvd., Camarillo, CA 93011
Visit our Web site at <http://www.harborfreight.com>

Copyright © 2004 by Harbor Freight Tools®. All rights reserved. No portion of this manual or any artwork contained herein may be reproduced in any shape or form without the express written consent of Harbor Freight Tools.

For technical questions and replacement parts, please call 1-800-444-3353

Specifications

Product Type	High Pressure Bucket Grease Pump
Capacity	22 lb. Grease
High Pressure Hose	2 meters x 1/4" I.D.
Features	Steel Extension 4 jaw Zerk Coupler Air Bleed Valve

Construction	Cast Iron Pump Steel Bucket
Bucket Dimensions	10-1/2"H x 9-1/2" diam.
Working Pressure	2000 psi
Empty Weight	19.6 lbs.

Save This Manual

You will need the manual for the safety warnings and precautions, assembly instructions, operating and maintenance procedures, parts list and diagram. Keep your invoice with this manual. Write the invoice number on the inside of the front cover. Keep the manual and invoice in a safe and dry place for future reference.

Safety Warnings and Precautions

WARNING: When using tool, basic safety precautions should always be followed to reduce the risk of personal injury and damage to equipment.

Read all instructions before using this tool!

1. **Keep work area clean.** Cluttered areas invite injuries.
2. **Observe work area conditions.** Do not use machines or power tools in damp or wet locations. Don't expose to rain. Keep work area well lit. Do not use electrically powered tools in the presence of flammable gases or liquids.
3. **Keep children away.** Children must never be allowed in the work area. Do not let them handle machines, tools, or extension cords.
4. **Store idle equipment.** When not in use, tools must be stored in a dry location to inhibit rust. Always lock up tools and keep out of reach of children.
5. **Use the right tool for the job.** Do not attempt to force a small tool or attachment to do the work of a larger industrial tool. There are certain applications for which this tool was designed. It will do the job better and more safely at the rate for which it was intended. Do not modify this tool and do not use this tool for a purpose for which it was not intended.
6. **Dress properly.** Do not wear loose clothing or jewelry as they can be caught in moving parts. Protective, electrically non-conductive clothes and non-skid footwear are recommended when working. Wear restrictive hair covering to contain long hair.

7. **Use eye and ear protection.** Always wear ANSI approved impact safety goggles. Wear an ANSI approved dust mask or respirator when working around metal, wood, and chemical dusts and mists.
8. **Do not overreach.** Keep proper footing and balance at all times. Do not reach over or across running machines.
9. **Maintain tools with care.** Keep tools sharp and clean for better and safer performance. Follow instructions for lubricating and changing accessories. Inspect tool cords periodically and, if damaged, have them repaired by an authorized technician. The handles must be kept clean, dry, and free from oil and grease at all times.
10. **Remove adjusting keys and wrenches.** Check that keys and adjusting wrenches are removed from the tool or machine work surface before plugging it in.
11. **Stay alert.** Watch what you are doing, use common sense. Do not operate any tool when you are tired.
12. **Check for damaged parts.** Before using any tool, any part that appears damaged should be carefully checked to determine that it will operate properly and perform its intended function. Check for alignment and binding of moving parts; any broken parts or mounting fixtures; and any other condition that may affect proper operation. Any part that is damaged should be properly repaired or replaced by a qualified technician.
13. **Replacement parts and accessories.** When servicing, use only identical replacement parts. Use of any other parts will void the warranty. Only use accessories intended for use with this tool. Approved accessories are available from Harbor Freight Tools.
14. **Do not operate tool if under the influence of alcohol or drugs.** Read warning labels on prescriptions to determine if your judgment or reflexes are impaired while taking drugs. If there is any doubt, do not operate the tool.
15. **Maintenance.** For your safety, service and maintenance should be performed regularly by a qualified technician.
16. **The grease gun and bulk grease must be stored out of reach of children.**
17. **The brass components of this product contain lead, a chemical known to the State of California to cause birth defects (or other reproductive harm). (California Health & Safety code 25249.5, et seq.)**

Warning: The warnings, cautions, and instructions discussed in this instruction manual cannot cover all possible conditions and situations that may occur. It must be understood by the operator that common sense and caution are factors which cannot be built into this product, but must be supplied by the operator.

Unpacking

When unpacking, check to make sure the following parts are included.

*High Pressure Cast Iron Grease Pump
22 lb. Capacity Steel Bucket
Spring Loaded Steel Follower Plate
2 Meter High Pressure Rubber hose
Fitted Steel Extension and Zerk Coupler*

If any parts are missing or broken, please call Harbor Freight Tools at the number on the cover of this manual.

Assembly

1. Remove all packaging material from the pump and its parts.
2. Thread the Lever Handle (1) into the Handle Bracket (2), and turn it clockwise until it is tight.
3. Open all 4 Cover Clamps (17), by lifting their handles up from the bottom, and letting their clamps fall away from the Drum Cover (5). Remove the complete Drum Cover (5) and Pump (10) assembly, set these aside.
4. Wipe out the Grease Drum (9) with a clean, dry rag to remove any contaminants that may be present.
5. Fill the Grease Drum (9) with up to 22 lbs. of bulk grease. Be sure to leave at least 1" from the top of the Grease Drum (9) unfilled, to make room for the pump and its components.

NOTE: Never put contaminated grease into the Grease Drum (9) as contaminants may damage the pump or the mechanism the grease is eventually pumped into. If grease is spilled onto the floor while filling, that grease should be discarded.

6. Place the Drum Cover (5) and Pump (10) assembly back onto the Grease Drum (9), with the Follower Plate (8) resting on the grease.
7. Push the Drum Cover (5) down onto the top of the Grease Drum (9). This will compress the Compression Spring (7), and will expel any air that might be trapped in the grease.
8. Reattach all four Cover Clamps (17), by positioning the clamp over the edge of the Drum Cover (5), and pressing the lever of the Cover Clamps (17) down to lock them closed. Your Grease Pump is now ready for operation.

Operation

Steel Extension (14)

NOTE: This pump is designed for use with petroleum based grease only. Do not use this pump for oil or other low-viscosity fluids, water-based materials, gasoline or other flammable liquids, or corrosive compounds. Do not use any materials which may damage the steel, iron, brass or nitrile rubber which make up the mechanism of this pump.

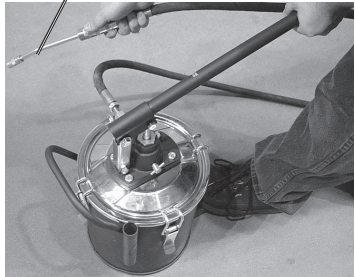

NOTE: On first use, you will have to pump several times until grease has filled the pump mechanism and the rubber hose. Point the Steel Extension (14) and Coupler (12) into an appropriate waste receptacle while pumping until grease is expelled from the Coupler (12).

WARNING: Never point the Steel Extension and Coupler toward any person or animal while pumping. Expelled grease under high pressure may cause severe injury.

NOTE: In the unlikely event that you are unable to get the grease to flow, it is likely that there is air trapped in the grease which is interfering with the action of the pump. To remedy this, open the Air Bleeder (16) by turning it counter clockwise a few turns by hand. Do not remove the Air Bleeder (16) from the pump. With the Air Bleeder (16) open, pump the handle until grease is expelled from the Air Bleeder (16). Close the Air Bleeder (16) by turning it by hand clockwise, until hand tight. Do not overtighten.

1. To operate the pump, attach the Coupler (12) to the grease fitting of the equipment being serviced. Hold the Coupler (12) in a straight line with the grease fitting on the machine, and ensure that the Coupler (12) is securely fastened.
2. Place one foot onto the Foot Rest (11), and pump the Lever Handle (1). Grease will flow from the pump into the machine being serviced. When the machine is full, grease will begin to escape from the overflow port on the machine. When you observe this, stop pumping.
3. To disconnect the Coupler (12), slightly tilt, twist and pull it off the grease fitting.

*Grease Pump with
Drum Cover removed*



Maintenance

1. When not in use, store the Steel Extension (14) in the vertical steel tube attached to the side of the Grease Drum (9).
2. Protect the Coupler (12) from damage. Wipe it with a clean rag before each use to prevent contamination of the grease being injected.
3. Store your Grease Pump in a clean dry place. Protect it from temperature extremes. Do not expose this tool to corrosive environments.
4. If you observe any grease leaking from the Air Bleeder (16), Discharge Outlet (15), or Coupler (12), check to be sure these parts are tightly installed.
5. Occasionally lubricate the pivot points of the Handle Bracket (2) and Connecting Link (4) with a medium weight oil.

Parts List

Part #	Description	Qty.
1	Lever Handle	1
2	Handle Bracket	1
3	Pump Head	1
4	Connecting Link	1
5	Drum Cover	1
6	Lift Handle	1
7	Compression Spring	1
8	Follower Plate	1
9	Grease Drum	1

Part #	Description	Qty.
10	Pump	1
11	Foot Rest	1
12	Coupler	1
13	Rubber Hose	1
14	Steel Extension	1
15	Discharge Outlet	1
16	Air Bleeder	1
17	Cover Clamp	4

NOTE: Some parts are listed and shown for illustration purposes only and are not available individually as replacement parts.

Assembly Drawing

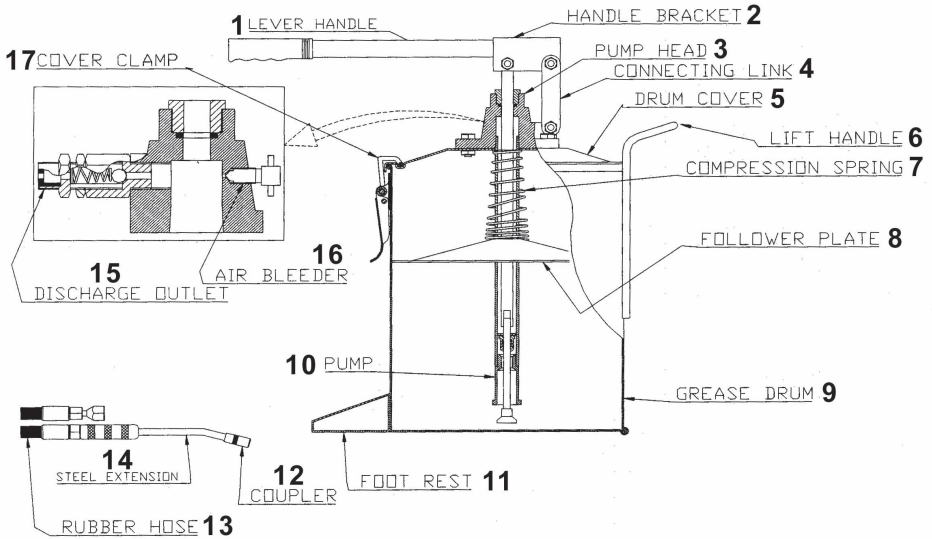

PLEASE READ THE FOLLOWING CAREFULLY

THE MANUFACTURER AND/OR DISTRIBUTOR HAS PROVIDED THE PARTS DIAGRAM IN THIS MANUAL AS A REFERENCE TOOL ONLY. NEITHER THE MANUFACTURER NOR DISTRIBUTOR MAKES ANY REPRESENTATION OR WARRANTY OF ANY KIND TO THE BUYER THAT HE OR SHE IS QUALIFIED TO MAKE ANY REPAIRS TO THE PRODUCT OR THAT HE OR SHE IS QUALIFIED TO REPLACE ANY PARTS OF THE PRODUCT. IN FACT, THE MANUFACTURER AND/OR DISTRIBUTOR EXPRESSLY STATES THAT ALL REPAIRS AND PARTS REPLACEMENTS SHOULD BE UNDERTAKEN BY CERTIFIED AND LICENSED TECHNICIANS AND NOT BY THE BUYER. THE BUYER ASSUMES ALL RISK AND LIABILITY ARISING OUT OF HIS OR HER REPAIRS TO THE ORIGINAL PRODUCT OR REPLACEMENT PARTS THERETO, OR ARISING OUT OF HIS OR HER INSTALLATION OF REPLACEMENT PARTS THERETO.